

CN1 SOURCE FROM CDPRO2M MODULE

DIGITAL INPUT

External Clock

JP4 Open : CS8414 Master Mode (JP1 Close JP2 & JP3 Open)
JP4 Close : CS8414 Slave Mode (JP1 & JP2 & JP3 Close)
JP4 Close : Exrnal I2S Mode (JP1 & JP2 & JP3 Open)

AC INPUT

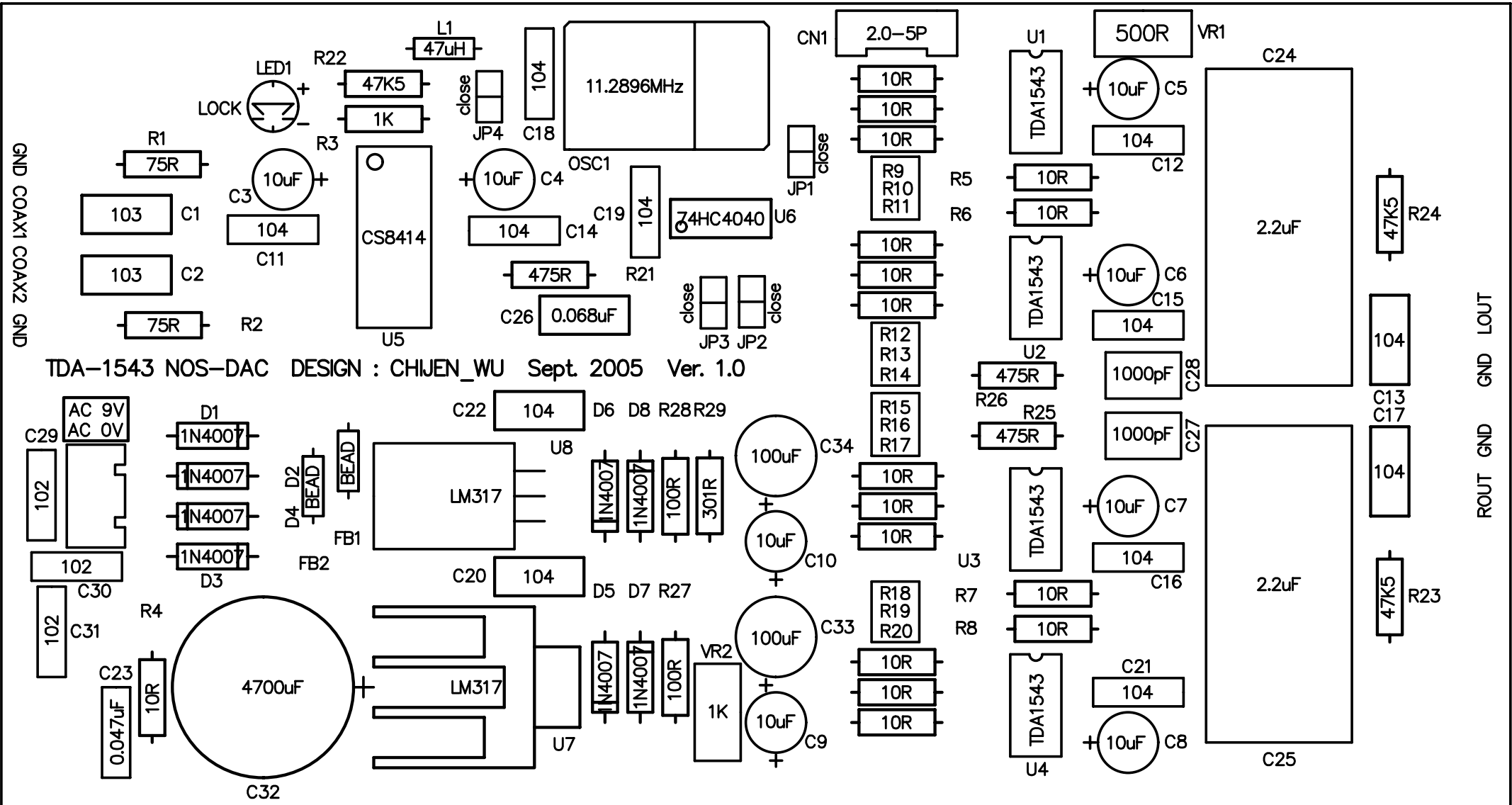

TDA-1543 NOS-DAC DESIGN : CHIJEN_WU Sept. 2005 Ver. 1.0

GND COAX1 COAX2 GND

ROUT GND GND LOUT

NOS-TDA1543 BOM LIST

廠牌	編號	零件數量
Cirrus Logic	CS8414	1
Dale	100R	2
Dale	10R	17
Dale	1K	1
Dale	301R	1
Dale	475R	3
Dale	47K5	3
Dale	75R	2
Fairchild	74HC4040	1
I2S連接線	250mm	1
IC腳座	8 Pin	4
Motorola	LM317	2
Nichicon MUSE	4700uF/16V	1
Oscillator	11.2896MHz	1
Philips	TDA1543	4
RIFA PHE450	2.2uF/250V	2
Sanyo OS-CON	100uF/10V	2
Sanyo OS-CON	10uF/25V	8
T20變壓器		1
25轉可變電阻	500R	1
25轉可變電阻	1K	1
WIMA FKP2	1000pF	2
WIMA MKS2	103	2
WIMA MKS2	104	12
WIMA MKS2	0.047uF	1
WIMA MKS2	0.068uF	1
二極體	1N4007	8
矽膠片		1
排針	2 Pin	4
連接座	2.0-5P	1
散熱片	K213	1
短路夾	2 Pin	4
絕緣豆		2
電感	47uH	1
電路板		1
磁珠	BEAD	2
積層電容	102	3
螺帽	3mm	1
螺絲	3 x 10 ⊕細牙	2
藍光 LED	3mm	1
電路板		1